

“Dose of Wisdom”

Back in July of last summer '15, I began a series of Newsletter articles dealing with The Book of Concord. The Book of Concord is a book of Lutheran writings that have helped shape and define what Lutherans believe, teach, and confess. We have looked at and reviewed the following writings and teachings of the Book of Concord; The Augsburg Confession, The Three Ecumenical Creeds, and The Smalcald Articles.

This month I would like to look at and review The Power and Primacy of the Pope. This is a “controversial” writing today as the Lutheran reformers called the ‘office of Pope’ the anti-Christ. This means that the office of pope drives people away from the grace and mercy of Christ by offering works for Christians to do to merit forgiveness. What follows below secondly is from *Concordia: The Lutheran Confessions* a book I would like to suggest to you to read this upcoming Lenten Season which starts on February 10th. I am posting a blog post by Joe Willmann from Concordia Publishing House dealing with reading through the Book of Concord during the season of Lent.

Let's Read the Book of Concord together for Lent!

JOE WILLMANN FEBRUARY 1, 2016 BLOG

I was thinking about what I was going to give up for Lent this year. I have done a lot of things in the past. I gave up salsa one year, all meat another year, and just red meat still another. But one thing I have found to be beneficial for my own edification is giving up my time. I have been choosing something to read in forty days that will take some dedication and sacrifice.

Q: Do Lutherans have to give up something for Lent as some other denominations require?

A: From the perspective of The Lutheran Church—Missouri Synod, “giving something up for Lent” is entirely a matter of Christian freedom. It would be wrong, from our perspective, for the church to make some sort of “law” requiring its members to “give something up for Lent,” since the Scriptures themselves do not require this. If, on the other hand, a Christian wants to give something up for Lent as a way of remembering and personalizing the great sacrifice that Christ made on the cross for our sins, then that Christian is certainly free to do so—as long as he or she does not “judge” or “look down on” other Christians who do not choose to do this.

From www.lcms.org

I decided this year I wanted to read through the Book of Concord. As Lutherans, we believe the Book of Concord to be an accurate description of what Holy Scripture teaches. Even if you have read all of the Confessions before, now would be a great time to go through them again! Will you join me? Below you will find a link to a forty-day reading plan for the Book of Concord with page references to *Concordia: The Lutheran Confessions, 2nd Edition*. If you decide to join me, feel free to discuss how it's going and what you are learning with me on Twitter! You can connect with me at either [@jtwillmann](https://twitter.com/jtwillmann) or [@cpheducation](https://twitter.com/cpheducation).

EDITOR'S INTRODUCTION TO THE TREATISE ON THE POWER AND PRIMACY OF THE POPE

We will show from the Gospel that the Roman bishop is not above other bishops and pastors by divine right.

—Philip Melancthon, Tr 7

How do Christians receive pastors? How is the Church organized, structured, and governed? The Roman Catholic answer is that everything depends on the pope, the “vicar of Christ,” the one who is said to be the immediate successor to the Apostle Peter. Through the pope, so it is thought, flows Christ’s authority to His Church on earth. This is not the Bible’s answer. In this document Philip Melanchthon provides the Lutheran view of authority in the Church and the basis on which the Church is founded and continued.

This Treatise on the Power and Primacy of the Pope is often considered an appendix to the Smalcald Articles. In reality, it is not. It was regarded as a follow-up to Augsburg Confession and the Apology. When Lutheran leaders in Smalcald gathered in February 1537 to consider Luther’s articles, most of them signed them, but they were not formally adopted by the Smalcaldic League. Instead, it was this Treatise that was adopted. The Smalcaldic League wanted some document that would provide their position on the papacy for the general council scheduled for Mantua. And so, at the end of their meeting, they adopted Melanchthon’s Treatise.

In the Treatise, Melanchthon presents the position Luther took in the Smalcald Articles on the Papacy (SA II IV). He said to a friend later, “I wrote this Treatise somewhat more sharply than I wanted” (*Corpus Reformatorum*, 3:271, 292). No doubt, Elector John Frederick insisted that Melanchthon write something clear and to the point, something that would not be misunderstood later.

The Treatise has two basic parts. The first (pars. 1–59) analyzes the claims made by the Medieval Church about the papacy down through the years. Rome claimed that the pope is the supreme head of the Church by divine right and, therefore, the pope has final and ultimate authority in both the Church and the world. Rome asserted that it is necessary for salvation to believe these things about papal authority because the pope is the vicar (representative) of Christ on earth. The assertion that the pope is the Antichrist strikes modern ears as radical, perhaps even offensive. The point simply is that the “marks of Antichrist plainly agree with the kingdom of the pope and his followers” (Tr 39). The reasons for this claim are provided in detail by Melanchthon. The second part (pars. 60–82) describes the power and jurisdiction of bishops (see note, pp. 302–3).

The foundation of all Roman Catholic arguments for the authority of the pope rests on the interpretation of Matthew 16:18 and John 21:15–17. Rome claims that Matthew 16:18 is the “proof text” for papal authority. The argument goes like this: The Lord chose St. Peter to be the head of the apostles, and as such, Christ promises to build His Church on Peter, the Rock. A careful study of the actual words of this text reveals that in fact Christ is playing off Peter’s name, “Petros,” to speak about the “Petra,” the rock-solid truth that Peter is expressing, namely, the truth about Christ. On the rock of Peter’s confession—not Peter himself—Christ says He is building His Church.

Church Authority Today

The Treatise is also very helpful for the proper understanding of the role of bishops and pastors in the Church today. Lutheranism rejects any suggestion that differences in the way clergy are ordered in the Church is a divine mandate. Orders and ranks in the clergy are a matter of human arrangement, in Christian freedom, for the sake of good order in the Church. However, every pastor is equal in office when it comes to the essence of the ministry: proclaiming the Gospel, administering the Sacraments, and other duties. As the Gospel is one, so the ministry of the Gospel is one.

Placing men into the pastoral office through ordination is something the church can always do through its pastors. The Gospel is what is at stake in these issues. The Gospel does not depend on anything but Christ for its validity and efficacy. So Melanchthon quotes Augustine favorably to explain that Christians can, and even should, administer Baptism to one another when a pastor is not available (e.g., an emergency Baptism).

Today, people still wonder whether Rome continues to insist on papal authority. The best way to answer that question is to look at the *Catechism of the Catholic Church*, the most definitive presentation of Roman Catholic doctrine since the Council of Trent in the sixteenth century. Just read paragraphs 880–87 and you will realize that the claims made by the Roman Catholic Church about papal authority, though

though clearly presented in gentler tones and also clearly more evangelical in nature, are still every bit as absolute. Therefore, the Treatise on the Power and Primacy of the Pope is as true and necessary today as it was in the sixteenth century.

The translation is from the 1584 Latin edition of the Book of Concord, which was the base text for the Treatise in the *Concordia Triglotta*. See the User's Guide on page xxvii for details about the use of brackets and symbols.

McCain, P. T. (Ed.). (2005). *Concordia: The Lutheran Confessions* (p. 291). St. Louis, MO: Concordia Publishing House.

McCain, P. T. (Ed.). (2005). *Concordia: The Lutheran Confessions* (pp. 291–292). St. Louis, MO: Concordia Publishing House.



Ash Wednesday

Please be sure to join us on Wednesday, February 10th for Ash Wednesday, as we begin our Lenten Journey. Services will be held at 11 am and at 7:00 pm each Wednesday evening until March 17th. A lunch will be served at noon. If you or a group would like to prepare a meal, please contact the office. The meals don't have to be anything fancy or large.

FRIENDS ARE

**TRUTHFUL
CARING
RELIABLE
HELPFUL
POLITE
INTERESTING
ALWAYS THERE
FOR YOU.**



LENTEN MEALS

We would like to try and get together a group of people who would like to cook some soup and make some light sandwiches for a meal following the services at 11 am during Lent. Adding a light meal would add to the fellowship aspect of our services.

Please let the office know if you would like to be one of those who puts together some sort of meal.



Feb 10	11:00 & 7:00	Ash Wednesday/ Holy Communion
Feb 17	11:00 & 7:00	Midweek Service
Feb 24	11:00 & 7:00	Midweek Service
Mar 02	11:00 & 7:00	Midweek Service
Mar 09	11:00 & 7:00	Midweek Service
Mar 16	11:00 & 7:00	Midweek Service
Mar 20	10:00	Palm Sunday/ Confirmation
Mar 24	11:00 & 7:00	Maunday Thursday/HC
Mar 25	11:00 & 7:00	Good Friday
Mar 26	6:00	Easter Vigil
Mar 27	8:00	Easter Service/HC

SHARE JESUS
WITH A FRIEND

L. Y.F. NOTES



Sub Sandwich Sales

They LYF has been taking Sub Sandwich orders for Super bowl Sunday. They will be making the sandwiches on Thursday, February 4th at 4 pm.. The sandwiches will be available for pick up or delivery. There will be some additional sandwiches made for those who did not place an order or who wish to purchase additional sandwiches. Remember they are great frozen for later use in addition to being served for Super bowl Sunday. Sandwiches are made with Roast Beef, Ham, turkey and 2 types of cheese, They are selling for \$3.50 each. Thank you for your support. It is appreciated.

Winter has settled into the Sunday School. Even though it is cold outside we have a lot of warm hearts inside due to the Good News of Jesus Christ being shared by our teachers and students.



February is Friendship Sunday month! We are working on a new song we will be presenting on February 14th along with observing Friendship Sunday Bring a friend. The more the merrier. We'll enjoy a snack and create Valentine's Day gift bags for some of the shut-in, elderly, sick, and nursing home bound. Want to help fill the bags? Bring Large-Print puzzle books (crosswords, word search, etc), coloring books (preferably ones with larger simple designs), small boxes of tissues, simple black combs, lip balm. These are just some ideas. Let's spread Jesus love.

Thank-you to everyone that helped with the Christmas Program, The children did an awesome job! We were worried some days but the kids and staff pulled it all together. Special thanks to the parents for making sure the kids were there

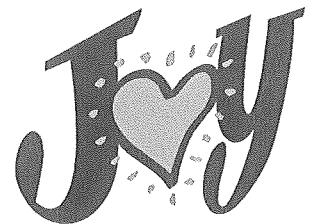

Women's
BIBLE
STUDY

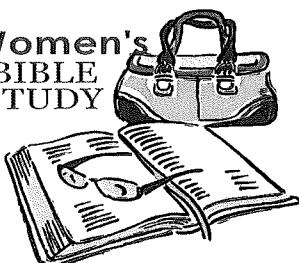

Our Women's Bible Study will meet on February 9th and February 23rd at 6:30 pm. All women are invited to attend. Each lesson stands alone, so come if and when you can.



Friendship Sunday --- February 14, 2016

WE WANT YOU TO INVITE SOMEONE!

You may not have done this before – but this year we want you to! Consider a neighbor, a friend, a relative, someone with whom you work, or see occasionally. They could be new to the area or someone who has been around for years. God wants you to invite them. The front entry of our church with its stain glass windows were designed to make people look, wonder, and want to come in – but the doors alone cannot do this. **WE'D LIKE YOU TO TAKE THE FIRST STEP**; the Holy Spirit will help. Offer to pick them up if there is any way you could work this out.

Come, join us and bring a friend or two! You'll learn some things which may surprise you and all those who come will not go away hungry.

FRIENDSHIP ABLAZE! MEANS BUILDING FRIENDSHIPS: Perhaps there is an acquaintance in your life who needs you to build a stronger friendship with him/her. Maybe it is your mechanic, your hair dresser, a neighbor, or a person at work. You are someone who can share the greatest Friend any of us will ever have. Now is the time to intentionally build that friendship. Spend time with that person. Remember birthdays, anniversaries. Share your times of joy and celebration with that person. Seek ways to help and encourage your friendship. This is how we set our friendships *Ablaze!*



We would like to welcome into baptized membership Cale Louis Dirks son of Matt & Kelli Dirks. Cale was baptized here at Zion on January 31st. Serving as sponsors were Melissa Bluml, Leesa Running & Travis Neumann. We pray God's blessings upon Cale and his family.



We offer our Christian sympathies to the family of Lester Popp. Lester was called home on January 28th and his mortal remains were committed on February 1st.



Work Hard,
Do Your Best,
Keep Your Word,
Never Get Too Big For Your Britches,
Trust In God
And Never Forget a Friend

Below is a Funeral Policy for luncheons here at Zion. Due to declining numbers in the L.W.M.L. Circles, they have implemented the following policy.

FUNERAL POLICY FOR LUNCHEONS

Funerals for persons attending Zion Lutheran Church in Arcadia, have 2 options for the funeral lunches.

Option 1

Funeral lunches where 100 or fewer persons are expected may be held in Zion's church basement if the family desires. Person from that month's Martha circle should be present while the caterers work .

Option 2:

Includes any groups of more than 100 persons will be held in a different location chosen by the family. Person from that month's Martha circle should be present while the caterers work

The lunches will be catered for both options. Caterers stay to work the dinner. Cake will be ordered from Hy-Vee and bill given to funeral home.

If the Zion Lutheran church basement is to be utilized, LWML Circle ladies MAY be responsible for the kitchen- help set up (the night before or day of), and clean up (this could be a different group of ladies).

The contact person for the funeral lunch arrangements will be Deb Owen, 712-689-2441, Zion Lutheran's Church secretary

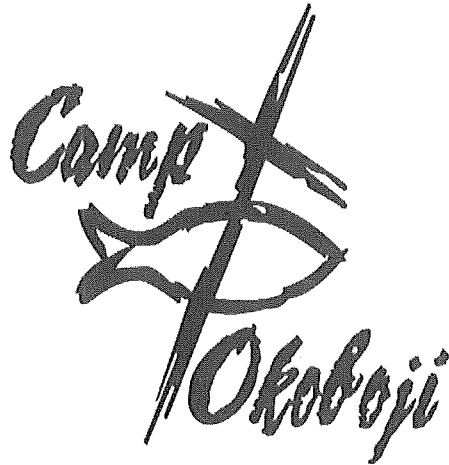

DISCOVER THE DIFFERENCE OF JESUS AT THE LAKE

All 2016 camps are ready for online registration. Go to www.campokoboji.org and **Discover** the opportunities for children, youth, families, and friends to register for an exciting, refreshing, and renewing retreat. Camp Okoboji is for people of all ages and provides facilities and programming to accommodate varied interests and activities. See Jesus at work in your life as well as the lives of friends and family. Please register early to be sure and get in to the retreat or camp you wish to attend.

Camp Okoboji will host an "All Church Worker Retreat" June 19-21, 2016. The Reverend Roger Sonnenberg will be the speaker for this event. He holds a Master of Divinity degree from Concordia Seminary in St. Louis, and a Master's degree in psychotherapy from the American Institute of Family Relations. Presently he serves as chairman of Family Shield in St. Louis, Missouri. Registration and schedule for the event are available online at www.campokoboji.org. It is open to Pastors, Teachers, Principals, DCEs, DCOs, Deaconesses, Parish Nurses, and all other professional church workers. This is an opportunity to connect with other professional church workers and gain insight into ministering to people with different lifestyles.

If you have never attended a camp event where the entire family can go together then you are in for a treat at one of the three family camps that are offered at **CAMP OKOBOJI**. July 3-9 is the **4th of July Family Camp**. July 31-August 6 is **Family Retreat 1**, and August 7-13 is **Family Retreat 2**. **Your entire family; grandparents, parents, and children can attend together**. A special topic leader is present for young adults and older, with other qualified topic leaders for high school, junior high, and grade school children. There is childcare available as well. Afternoons are loosely structured to allow for families to reconnect on or off site, and the evening is spent in relaxed Christian settings for all retreaters. Go to www.campokoboji.org to register online. You can also see more details about the topic and view the schedule and fees for each of these wonderful family gatherings.

Do you need to get a new outlook on life? Do you need to see yourself through the eyes of Jesus? How is your relationship with God and family? Come to **CAMP OKOBOJI** to see the lake, view your relationship with God and family through the eyes of the Gospel, and see others as God sees them. Camp Okoboji is the center for discovering the difference and strengthening relationships with God, self, family and friends. Spend some time in God's creation with Jesus at the Lake.

February 2016

SUNDAY	MONDAY	TUESDAY	WEDNESDAY	THURSDAY	FRIDAY	SATURDAY
	1 <i>Shut in visits Carroll</i>	2	3 <i>9:30 Bible Study 2:00 Midweek 7:00 Evening Cir</i>	4 <i>4:00 Make Subs</i>	5	6 <i>6:00 DW/HC</i>
7 <i>9:00 Chr. Ed 10:00 DW/HC</i>	8 <i>Shut in visits Westside/Manning</i>	9	10 <i>9:30 Bible Study 11:00 Ash Wed/HC 4:00 Midweek 7:00 Ash Wed/HC</i>	11	12	13
14 <i>9:00 Chr. Ed 10:00 DW</i>	15 <i>Shut in visits Arcadia</i>	16	17 <i>9:30 Bible Study 11:00 Lenten Wor 2:00 Midweek 7:00 Lenten Wor 7:30 Council Meet</i>	18	19	20
21 <i>9:00 Chr. Ed 10:00 DW/HC</i>	22	23	24 <i>9:30 Bible Study 11:00 Lenten Wor 4:00 Midweek 7:00 Lenten Wor</i>	25	26	27
28 <i>9:00 Chr. Ed 10:00 DW</i>						

USHERS

Dwight Ehlers
 Brian Kraus
 Curtis Ehlers
 Brad Hinners
 Colton Neumann
 Randy Neumann
 Jake Kraus
 Dale Lenz
 Zack Kraus
 Ryan Neumann

CHANCEL CIRCLE

Paulette Von Glan
 Marilyn Mueggenberg

PARISH CIRCLE

Paulette Von Glan
 Marilyn Mueggenberg

ACOLYTES

7th: Dalton Ehlers & Jonathan Dose
 14th: Katelyn Hinners & Damon Ehlers
 21st: Makayla Hinners & Bret Hinners
 28th: Kalon Cleveland & Kyelar Cleveland

MIDWEEK SERVERS

3rd: Denise Ragaller (2 pm)
 10th: Kate Neumann
 17th: Diane Schurke (2 pm)
 28th: Kim Cleveland

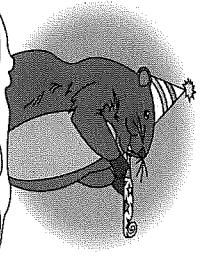

FEBRUARY
BIRTHDAYS & ANNIVERSARIES

February
2016

SUNDAY	MONDAY	TUESDAY	WEDNESDAY	THURSDAY	FRIDAY	SATURDAY
	1 <i>Camille Mumm</i>	2 <i>Jeremy Ewoldt</i>	3 <i>Spencer Owen Denise Ragaller Kendyl Riesberg Grant Wilken</i>	4 <i>Olivia Mau</i>	5 <i>Cassie Neumann Paulette Von Glan Leonard & Marilee Reetz</i>	6 <i>Al & Sandy Hunter</i>
7 <i>Hannah Kraus Roger Lee Nolan Vetter</i>	8	9 <i>Donna Schurke</i>	10 <i>Dane Dirks Mary Lou Kraus</i>	11 <i>Dennis Maasen Marilyn Mumm</i>	12	13
14 <i>Shayna Himmers Trama Vetter Jacob Wittrock Roger & Joyce Lee</i>	15 <i>Dylan Vetter Jim & Patty Vetter</i>	16 <i>Calx Goetz Emilie Hanson Ryan Middleton</i>	17 <i>Brandon Himmers Lilly Julin Lacey Middleton Ann Whitaker</i>	18 <i>Wyatt Ragaller</i>	19 <i>Emily Witt</i>	20 <i>Jane Haggge</i>
21	22 <i>Mary Erps Brian Hausman</i>	23	24 <i>Janice Wilken</i>	25 <i>Doug Kahl Tony Mumm Gavin Thiedeman</i>	26	27
28 <i>Wilbert Ehlers Emmalee Julin Emily Weller Randy & Mary Bruhn</i>	29					

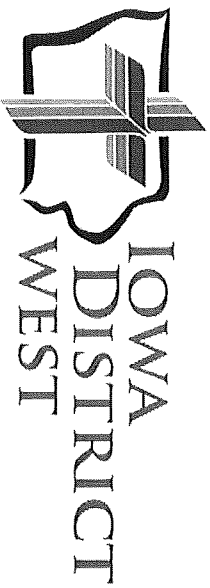

Planting Together

February 2016

409 Kenyon Road, Suite B — Fort Dodge, Iowa 50501
515-576-7666 Fax 515-576-2323 www.idwlcms.org
Contact email: sue.light@idwlcms.org

On a Mission to Support Christ's Mission!

End of Year Harvest Time

When the harvest comes in on the farms, the farmers sometimes have to work 20 hours a day, because they must get the harvest in while there is still time.

It's that way at the Lord's Mission Central also! At the end of the year in December the HARVEST of blessings come in and we are just swamped with so much of a blessing. The Lord Jesus said in Matthew 9:37-38: "The harvest is plentiful but the workers are few. Ask the Lord of the harvest, therefore, to send out workers into the harvest field" ... and THAT'S JUST WHAT HAPPENED at Mission Central. We prayed that the Lord would send us volunteer helpers to assist with the Harvest here and HE ANSWERED our prayers. God provided three new workers to help with our year-end work of handling the huge amount of blessings that the Lord sent to us!



We ask for help at harvest time and He answers. The Lord provided a wonderful harvest with record yields for our crops, and record gifts here and wonderful helpers. We must not forget to thank and praise the Lord for answering our prayers. We forget that some times...that we MUST THANK AND PRAISE OUR HEAVENLY FATHER FOR PROVIDING FOR US...just when we needed it! Thank you Lord for providing everything we have and help us to understand it's truly a gift from you! Help us to remember the only decision in this life is how much of Your gifts we are going to return to You!

Gary Thies, Director-Mission Central
Gary.Thies@idwlcms.org

Scholarships Available from Lutheran Church Extension Fund
Six \$1,000 LCEF upper Midwest districts scholarships will be awarded this year. Your college choice can be anywhere, as long as it is accredited. Awards are not based upon the type of degree you are pursuing. Students must be a current LCMS member of Iowa Districts East or West, Minnesota North or South, North Dakota, North or South Wisconsin. Graduating seniors and current college students should visit www.lcefuppermidwest.org/scholarships for qualification details and application. Apply before February 28, 2016.

ILSTO Update

We are pleased to announce that in 2015 the Iowa Lutheran School Tuition Organization (ILSTO) reached its goal and raised over \$790,000 for tuition assistance. Because of your support, families and students will receive financial help to attend Lutheran elementary and secondary schools in Iowa for the 2016-2017 school year. Our goal for 2016 will increase to \$822,535. Thank you for your generosity and your part in the Lord's work. (Dewey Torkelson—ILSTO Program Manager)

Missions Banquet

How about traveling to St. Paul Lutheran Church, Carroll to hear what other congregations are doing in IDW to connect with their communities? Sunday, March 13 (registration 4:30, program 5:00) is the date for this year's Missions Banquet. Not only will this year's mission grants be awarded, but you'll have a chance to hear from some of last year's recipients, network with those present, and enjoy a FREE meal! Go to www.idwlcms.org to register.

Around the District

Did you notice the "new" page in The Monthly? Titled "Around the District," this page will include information from congregations regarding guest speakers, events, or special occasions. If you'd like to invite others in the District, please let us know and we will share it "Around the District." Send information to Sue (sue.light@idwlcms.org) at the District office.

District Calendar

February 16... District Board of Directors, Fort Dodge
February 16-17... Synod President Matthew Harrison and Fifth Vice President Nabil Nour visit the District
March 12... LERT Training, Trinity, Des Moines
March 13... Missions Banquet, St. Paul Carroll
April 11-12... District Pastors Conference, Sioux City

For more information on Iowa District West activities, view *The Monthly* at <http://www.idwlcms.org/publications.php>.



What is Happening at your Camp?
1531 Edgewood Drive
Milford, IA 51351
712-337-3325 or
866-449-3326

E-mail: camp@campokoboji.org

Website: www.campokoboji.org

Our Promise of Jesus at the Lake

A friendly, safe, refreshing and relaxing Christian experience
An excellent value for you and your family

Upcoming Events

- February Online Registration Continues!
- February 14-18 NLOMA Conference & Joint Recruitment
- February 26-27 C.H.A.O.S.

DISCOVER CAMPAIGN OKOBOJI

DISCOVER CAMPAIGN OKOBOJI tops the \$900,000 mark in gifts and pledges! Congregations are encouraged to participate in this campaign. Materials are available from the Camp office. Camp friends are also asked to continue supporting this campaign. The \$250,000 Matching Gift Challenge has not yet been met. Please join us on this great project.

Thrivent Financial Offers Ways to Support Camp Okoboji

1. Choice Dollar designations from Thrivent members impact several Camp areas.
2. Action Teams: Last year, 22 Action teams benefited Camp Okoboji. We would like to double that number this year.

Contact Camp for a list of possible support areas or share your ideas with us. We can help with the process. Contact Paul Golke at 712-360-0550.

C.H.A.O.S. - Christians Hyped About Our Savior!

Our 9th Annual Jr. High winter event will take place **February 26-27, 2016!** Register online TODAY! DCE Tim Kightlinger from Gloria Dei Lutheran Church in Urbandale will be our Bible study leader for this event. Games and recreation are being planned by DCE Bethany Kuhlmann from St. John in Honey Creek and Lay Minister Jessica Long from Our Savior in Denison. Music will be led by Pastor Richard Merrill from St. John in Charter Oak and Vicar Isaac Johnson from Our Savior in Denison.

CAMP OKOBOJI SUMMER EMPLOYMENT AND VOLUNTEER COUNSELORS!

Go to www.campokoboji.org and check out the opportunities available for summer employment! We have openings in housekeeping, grounds maintenance, lifeguards, traveling VBS teams, and of course our volunteer counselors for our youth camps. Applications for all of these can be found on the website. You can also apply for employment by going to www.nloma.org and filling out the application there. DON'T DELAY!

WINTER RETREAT LODGING AT CAMP OKOBOJI

Camp Okoboji has almost 300 beds in heated facilities and is open all year. If you are looking for a location for a **winter retreat, snowmobiling, snowshoeing or cross country skiing, or a family or friends gathering place** Camp Okoboji can accommodate most groups. All camp roads and sidewalks to heated facilities have snow removal. Call 866-449-3326 to make a reservation.

SUMMER CAMPS AND RETREATS

Online Registration is now available. Get your spots early. See all the opportunities for you and your family for this summer. There are youth camps and family camps with openings. What an awesome way to pass on the faith to your children or grandchildren – send them to Camp or bring them to Camp to experience Jesus at the Lake. Bring friends!



FACEBOOK!

"Like" us on Facebook

www.facebook.com/CampOkoboji-LCMS

Watch for upcoming events. See pictures of events and more!

Camp Staff Contact Information!

Executive Director: Doug Kading doug@campokoboji.org

Office Director: Kellie Jones kellie@campokoboji.org

Program Director: Lori Gamble lori@campokoboji.org

Ministry Advancement Director: Paul Golke paul@campokoboji.org

Financial Director: Karrie Mullenburger karrie@campokoboji.org

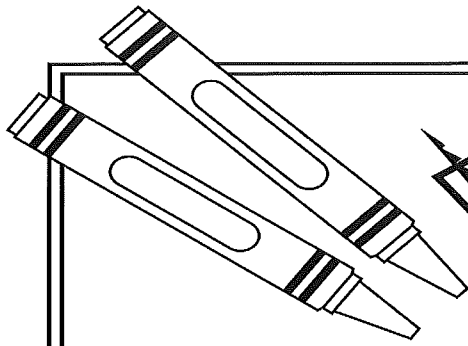

PUZZLE

Conversation hearts

The world encourages people to look out for themselves and seek success, but in Micah 6:8, God tells us to live differently.

Directions: Put the conversation hearts in the correct order by writing the words on the lines below. Hint: Capitalization and quotation marks are included.

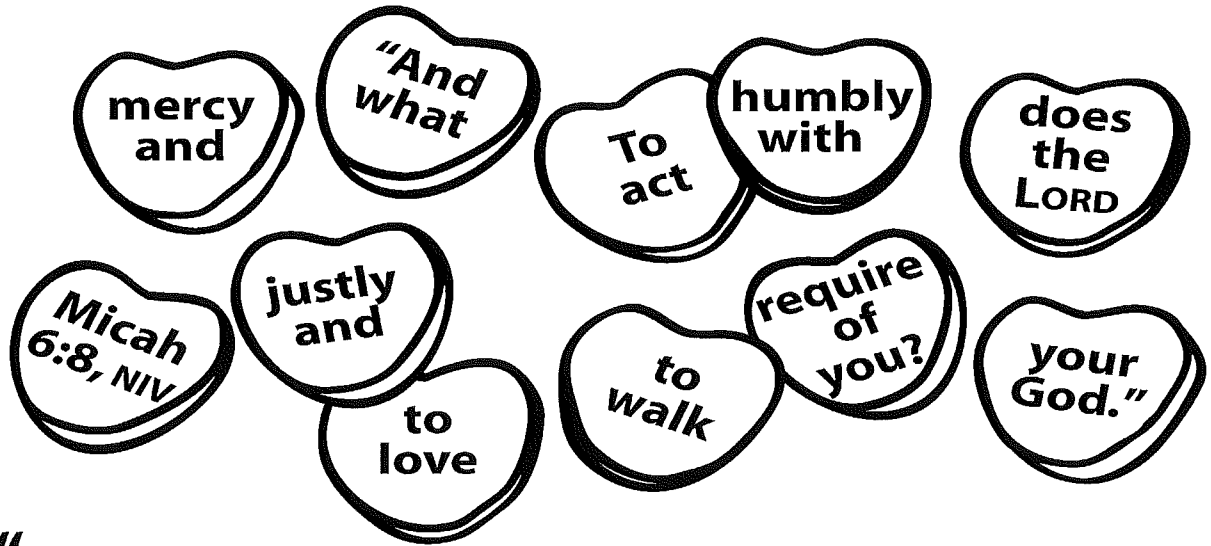

"

_____ ? _____

_____ " _____ 6:8 _____

Answer: "And what does the LORD require of you? To act justly and to love mercy and to walk humbly with your God." Micah 6:8, NIV

The Holy Alphabet

(Whoever came up with this one must have had some Divine guidance!)

Although things are not perfect
Because of trial or pain
Continue in thanksgiving
Do not begin to blame
Even when the times are hard
Fierce winds are bound to blow
God is forever able
Hold on to what you know
Imagine life without His love
Joy would cease to be
Keep thanking Him for all the things
Love imparts to thee
Move out of "Camp Complaining"
No weapon that is known
On earth can yield the power
Praise can do alone
Quit looking at the future
Redeem the time at hand
Start every day with worship
To "thank" is a command
Until we see Him coming
Victorious in the sky
We'll run the race with gratitude
Xalting God most high
Yes, there'll be good times and yes some will be bad, but...
Zion waits in glory...where none are ever sad!

"I AM Too blessed to be stressed!" The shortest distance between a problem and a solution is the distance between your knees and the floor.
The one who kneels to the Lord can stand up to anything. Love and peace be with you forever, Amen.

JESUS, MY SPECIAL FRIEND

When the troubles of this world crowd my
mind, I turn to Jesus every time

I tell Him all that in my heart
So he can do his work of art
On my thoughts, my fears and doubts
He dries my tears and drives evil out
He has never told a secret yet
An He understands me you can bet

He treats me go gentle and so kind and
Holds me close to Him at times
Sometimes I can almost hear him whis-
per "I love you, please don't cry" He gives
me strength to carry on
When I have thought and cried till dawn
He is the very best kind of friend
On Him I can always depend

He is never too busy to listen to me and
He fills my heavy heart with glee
I hope I can be the kind of friend to Him
as He has always been to me

Kay Harrison

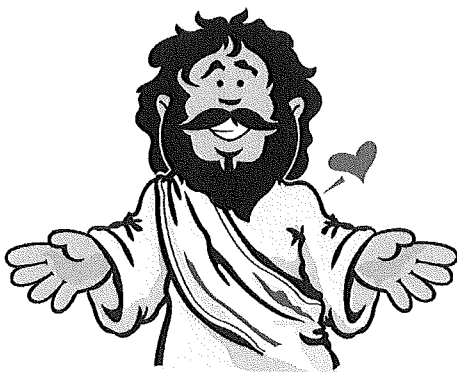

Jesus
Our True Friend



"A friend loves
AT ALL TIMES."

PROVERBS 17:17, NRSV

A Friend in Jesus"

Who could I turn to?
There's no one, but you,
My Savior who loves me,
Guides me each day through.

My Savior, who's there,
When I need a friend,
Always ready and able,
For my problems, to tend.

My Savior, who's there,
When I'm down sick or crying,
Even when my life's path,
Full of knots needs untying.

What could I say?
Your love shines forever,
Burning in my heart,
Lighting any stormy weather.

What back, could I give?
But just words, I love you
And what back might I ask,
Knowing you love me too.

Thank you, my Savior,
You're my real true friend,
You gave your life for me,
And on you I can depend.

ChrisRS ®©1986
"All Rights Reserved"

Refocus for Lent

Give up complaining — focus on gratitude.
Give up harsh judgments — think kind thoughts.
Give up worry — trust God to provide.
Give up discouragement — be full of hope.
Give up bitterness — turn to forgiveness.
Give up hatred — return good for evil.
Give up anger — be more patient.
Give up pettiness — become mature.
Give up jealousy — pray for trust.
Give up gossiping — control your tongue.
Give up sin — turn to virtue.
Give up giving up — persevere.

—Author unknown

Mealtime as a family

Amid busy and varied schedules, many families find a way to sit down together for dinner regularly. Family-health advocates describe the benefits: an increased sense of unity, children sharing news and feeling listened to, and the physical perks of a planned, seated meal.

In Scripture, many great encounters between people and God happen around meals. Abraham and Sarah prepare a meal for three guests who turn out to be angels (Genesis 18). God instructs the Hebrew slaves to eat a special meal together before their delivery from Egypt (Exodus 12); every year since, Jews have celebrated the Passover feast. Elijah is strengthened with food served by an angel (1 Kings 19). Jesus shares meals not only with religious leaders but with “sinners” (e.g., Matthew 9). Jesus’ Last Supper with his disciples before his death has become one of the church’s sacraments and a “foretaste” of the heavenly banquet to come.

When Christian families eat together, it’s a holy time in God’s presence, just as when the church shares Holy Communion — a true fellowship dinner!

“Teach us to love”

O God, perfect us in love,
That we may conquer all selfishness and hatred of others;
Fill our hearts with thy joy,
And shed abroad in them thy peace which passeth understanding;
That so those murmurings and disputings
To which we are too prone may be overcome.
Make us long-suffering and gentle,
And thus subdue our hastiness and angry tempers,
And grant that we may bring forth the blessed fruits of the Spirit,
To thy praise and glory, through Jesus Christ our Lord. Amen.

—Rev. Henry Alford (1810-1871)

Zion Lutheran Church
118 W Tracy St
Box 59
Arcadia, IA 51430
Rev Ben Dose
712-689-2441

Non-Profit Organization
Arcadia, IA 51430
Standard Mail

<i>Friends Who Care</i>	
<i>Christian Education</i>	<i>9:00 am</i>
<i>Divine Worship</i>	<i>10:00 am</i>

Friendship Sunday



February 14, 2016