

**Zion Lutheran Church
Box 59
Arcadia, IA 51430
712-689-2441**

The Board of Elders meets monthly at the Church. Please feel free to contact any member of the Elder Board about any aspect of our ministry here at Zion.

Please feel free to contact any member of the Elder Board about any aspect of our ministry here at Zion.

Ryan Middleton: Cell: 712-830-3396

**Randy Bruhn: Home 775-2692 Cell: 712-790-2491
email: mary@randysdiesel.com**

**Doug Ehlers Home 663-4449 Cell: 712-830-0062
Email: daehlers@westianet.net**

Kyle Bass Home Cell: 712-292-8830

**Scot Muhlbauer Cell 712-830-5582
Email: muhlbauerss@gmail.com**

**Kevin Skinner Cell 712-830-4884
Email: kskinner@westianet.net**

CHURCH COUNCIL

President:	Jeff Luetje
Vice President	Chris Toft
Secretary	Kathy Kraus
Treasurer	Mary Bruhn
Bd Evangelism	Shellie Lenz
Bd Education	Chad Wittrock
Bd Stewardship	Lajeane Shiney
Financial Sec.	Paulette Von Glan
Trustees:	Dwight Ehlers, Curtis Ehlers, Roger Liechti

"Noble Note"

"FOR US"

"*For us*" is a simple, yet powerful phrase. With only two small words, it conveys purpose and intentionality. It defines who it is for. And best yet, you and I are included in that! This little phrase packs within it a profound depth of the gospel. It proclaims that everything God has done has been "*for us*". The beauty and workings of this world is "*for us*". The promise of salvation handed down from Adam, Abraham, Israel, and lastly Mary was "*for us*". God willingly entered into the very world He spoke into being, and "*for us*", He suffered and died on the cross in our place. Then, on the third day, Jesus rose from the dead, holding the keys of death and life in His hands, ascended into heaven, and reigns over all of creation "*for us*". And now, in our days, Jesus continues His mission and work through His people, the Church, in order to make it known that it was all accomplished "*for us*".

Our focus for this upcoming Lenten season will be centered around this blessed phrase, "*for us*". And to guide our journey through this focus, we will be utilizing the hymn, "*O Love, How Deep*" (LSB 544). This hymn was originally a twenty-three-stanza poem written in the 15th century. But, because the singer-songwriter, *Meatloaf*, ruined long songs for us all, it was later narrowed down in size by an Anglican priest named Benjamin Webb to contain only six stanzas.

Some hymns tell a story, others teach doctrine, and still others do both by creating elegant, life-like pictures in our minds of the great works of God done "*for us*". "*O Love, How Deep*" is that kind of hymn. It takes Jesus' life and ministry and personally applies it to our own lives and brings it into our families and homes, into our work and school, into every situation we find ourselves in. Jesus came not for Himself, but as we declare within the Nicene Creed, Jesus came: "*for us and our salvation.*"

*For us baptized, for us He bore,
His holy fast and hungered sore;
For us temptation sharp He knew,
For us the tempter overthrew.*

*For us He prayed; for us He taught;
For us His daily works He wrought.
By words and signs and actions thus,
Still seeking not Himself but us. (LSB 544. Vs 3-4)*

*In His Service,
Pastor Noble*

EVENING CIRCLE

Will hold their meeting on Wednesday February 4th at 1:30 pm at the church.

Sub Sandwich Sales

They LYF has been taking Sub Sandwich orders for Super bowl Sunday. They will make the sandwiches on Wednesday, February 4th. Remember they are great frozen for later use in addition to being served for Super bowl Sunday. Sandwiches are made with Roast Beef, Ham, turkey and 2 types of cheese or you can order Italian, peperoni, salami and provolone cheese. They are selling for \$5 Thank you for your support. It is appreciated.



FREE SENIOR MEAL

WHEN: Tuesday, February 17, 2026

TIME Meals will be delivered at noon

Contact one of the following to place your order

Deb @ Zion Lutheran Church 689-2441
Diane Witt 689-2233

**Sponsored by Zion Lutheran Evening Circle
Thrivent Action Team/Project**

Winter has settled into the Sunday School. Even though it is cold outside we have a lot of warm hearts inside due to the Good News of Jesus Christ being shared by our teachers and students.

Thank-you to everyone that helped with the Christmas Program, The children did an awesome job! We were worried some days but the kids and staff pulled it all together. Special thanks to the parents for making sure the kids were there



Please be sure to join us on Wednesday, February 18th , for Ash Wednesday, as we begin our Lenten Journey. The theme this year is "For Us ". Worship will begin at 6:30 pm.



February 18	6:30 pm Ash Wednesday/HC
February 25	6:30 pm Midweek Service
March 04	6:30 pm Midweek Service
March 11	6:30 pm Midweek Service
March 18	6:30 Midweek Service
March 25	6:30 Midweek Service
March 29	10:00 Palm Sunday
April 02	6:30 Maunday Thursday/HC
April 03	6:30 Good Friday
April 05	7:00 Easter Service/HC

LUTHERAN WITNESS

If you would like to renew or become a new subscriber to the Lutheran Witness, please contact the church office by Sunday, February 22nd . The cost is \$31.10 for a year.



Work Hard,
Do Your Best,
Keep Your Word,
Never Get Too Big For Your Britches,
Trust In God
And Never Forget a Friend



Friendship Sunday --- February 15, 2026

WE WANT YOU TO INVITE SOMEONE!

You may not have done this before – but this year we want you to! Consider a neighbor, a friend, a relative, someone with whom you work, or see occasionally. They could be new to the area or someone who has been around for years. God wants you to invite them. The front entry of our church with its stain glass windows were designed to make people look, wonder, and want to come in – but the doors alone cannot do this. **WE'D LIKE YOU TO TAKE THE FIRST STEP**; the Holy Spirit will help. Offer to pick them up if there is any way you could work this out.

Come, join us and bring a friend or two! You'll learn some things which may surprise you and all those who come will not go away hungry.

BUILDING FRIENDSHIPS: Perhaps there is an acquaintance in your life who needs you to build a stronger friendship with him/her. Maybe it is your mechanic, your hair dresser, a neighbor, or a person at work. You are someone who can share the greatest Friend any of us will ever have. Now is the time to intentionally build that friendship. Spend time with that person. Remember birthdays, anniversaries. Share your times of joy and celebration with that person. Seek ways to help and encourage your friendship. This is how we set our friendships *Ablaze!*

Work Hard,
Do Your Best,
Keep Your Word,
Never Get Too Big For Your Britches,
Trust In God
And Never Forget a Friend

The Holy Alphabet

(Whoever came up with this one must have had some Divine guidance!)

Although things are not perfect
Because of trial or pain
Continue in thanksgiving
Do not begin to blame
Even when the times are hard
Fierce winds are bound to blow
God is forever able
Hold on to what you know
Imagine life without His love
Joy would cease to be
Keep thanking Him for all the things
Love imparts to thee
Move out of "Camp Complaining"
No weapon that is known
On earth can yield the power
Praise can do alone
Quit looking at the future
Redeem the time at hand
Start every day with worship
To "thank" is a command
Until we see Him coming
Victorious in the sky
We'll run the race with gratitude
Xalting God most high
Yes, there'll be good times and yes some will be bad, but...
Zion waits in glory...where none are ever sad!

"I AM Too blessed to be stressed!" The shortest distance between a problem and a solution is the distance between your knees and the floor.
The one who kneels to the Lord can stand up to anything. Love and peace be with you forever, Amen.

JESUS, MY SPECIAL FRIEND

When the troubles of this world crowd my
mind, I turn to Jesus every time
I tell Him all that in my heart
So he can do his work of art
On my thoughts, my fears and doubts
He dries my tears and drives evil out
He has never told a secret yet
An He understands me you can bet

He treats me go gentle and so kind and
Holds me close to Him at times
Sometimes I can almost hear him whis-
per "I love you, please don't cry" He gives
me strength to carry on
When I have thought and cried till dawn
He is the very best kind of friend
On Him I can always depend

He is never to busy to listen to me and
He fills my heavy heart with glee
I hope I can be the kind of friend to Him
as He has always been to me

Kay Harrison



Jesus
Our True Friend



"A friend loves
AT ALL TIMES."

PROVERBS 17:17, NRSV

A Friend in Jesus"

Who could I turn to?
There's no one, but you,
My Savior who loves me,
Guides me each day through.

My Savior, who's there,
When I need a friend,
Always ready and able,
For my problems, to tend.

My Savior, who's there,
When I'm down sick or crying,
Even when my life's path,
Full of knots needs untying.

What could I say?
Your love shines forever,
Burning in my heart,
Lighting any stormy weather.

What back, could I give?
But just words, I love you
And what back might I ask,
Knowing you love me too.

Thank you, my Savior,
You're my real true friend,
You gave your life for me,
And on you I can depend.

ChrisRS ©1986
"All Rights Reserved"

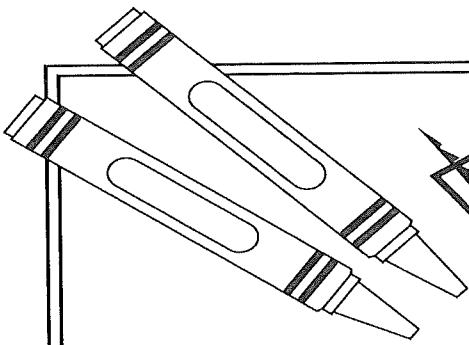

PUZZLE

Conversation hearts

The world encourages people to look out for themselves and seek success, but in Micah 6:8, God tells us to live differently.

Directions: Put the conversation hearts in the correct order by writing the words on the lines below. Hint: Capitalization and quotation marks are included.

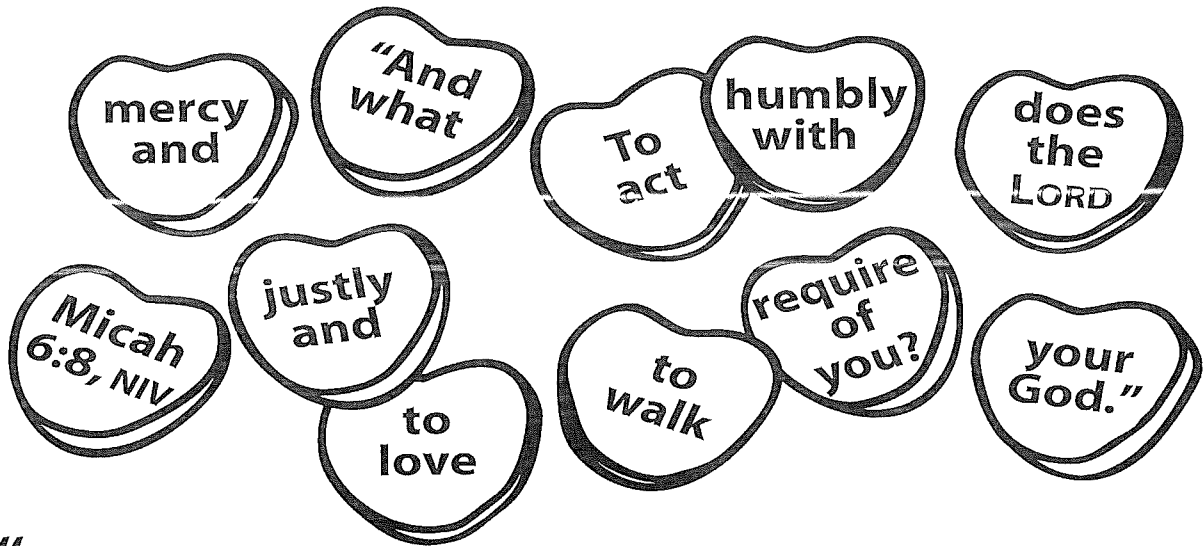

"

_____ ? _____

_____ " _____ 6:8 _____

Answer: "And what does the LORD require of you? To act justly and to love mercy and to walk humbly with your God." Micah 6:8, NIV

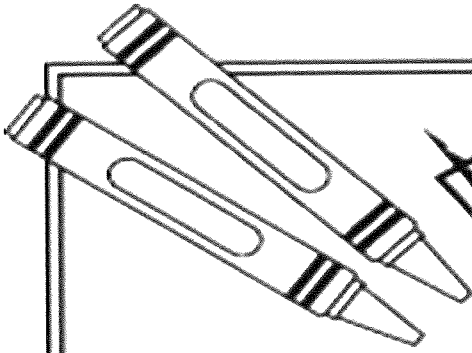

PUZZLE

A NEW COMMANDMENT

In John 13:34, Jesus offers important instructions for his followers.

Directions: Figure out the pattern in each vertical line of letters. Then add the next letter in the sequence to the blank underneath, completing John 13:14, NIV.

ABCDEFGHIJKLMNOPQRSTUVWXYZABCD...

F	L	S	Y	F	K	Y	X	E	I	Q	B	V	O	O	J	F
H	M	T	A	I	L	A	Y	H	K	R	D	Y	P	S	M	G
J	N	U	C	L	M	C	Z	K	M	S	F	B	O	W	P	H

E	X	M	B	C	L	M	B	U	V	F	R	P	L	V	F	R
F	Y	P	C	F	M	P	C	X	W	I	S	Q	M	W	I	S
G	Z	S	D	I	N	S	D	A	X	L	T	R	N	X	L	T

A	R	J	Q	C	C	S	B	F	K	Y	X	H	L	Q	B	Y	I
E	S	M	R	F	G	T	C	I	L	A	Y	J	M	R	D	A	L
I	T	P	S	I	K	U	D	L	M	C	Z	L	N	S	F	C	O

JOHN 13:34, NIV

Answer: "Love one another. As I have loved you, so you must love one another." John 13:34, NIV

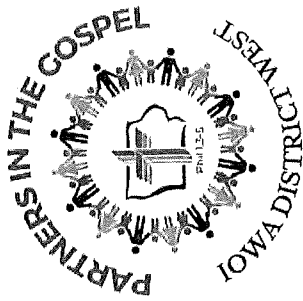

On a Mission
to Support
Christ's Mission!

409 Kenyon Road, Suite B — Fort Dodge, Iowa 50501
515-576-7666 Fax 515-576-2323 www.idwlcms.org
Contact email: emilie@iowadistrictwest.org

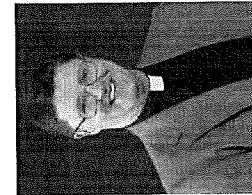

Sharing the Light of Christ Around the World

Epiphany greetings from all of us at Mission Central, where we have the joy of raising mission awareness among the congregations of our district. Whenever I have the opportunity to share the exciting news about what the Lord is doing in His mission fields, it is always my intention to encourage God's people to a deeper appreciation for the gifts that Jesus brings to them each week in Word and Sacrament, and to provide them with opportunities to pray for and support our missionaries who bring these same Means of Grace to lost souls around the world. I also endeavor to encourage our young people to prayerfully consider a vocation as full-time church professionals and maybe even as career missionaries. It would be a great privilege for me to visit your congregation and share with you stories and pictures from around the world, as our missionaries tell others the Good News about Jesus. As we prepare to enter the season of Lent on February 18th, we rejoice that we have a Savior who lived a perfect life in our place as our substitute, who died on the cross to take the punishment that we deserve, and who rose again from the dead to give us a new life with Him that will last forever. This joy and peace – this hope and certainty – is ours! That's why we share Christ with our neighbors and with the world, so they can have what we have and rejoice together with us in the blessed assurance of sins forgiven and eternal life with Jesus.

Steve Schulz, Assistant Director, Mission Central

Steve.schulz@lcms.org



IOWA LUTHERAN SCHOOL
TUITION ORGANIZATION
PHILADELPHIA, PA 19104

We are deeply grateful to all our generous donors for your incredible support in 2025! Thanks to you, the Iowa Lutheran School Tuition Organization (ILSTO) successfully raised \$500,000, which will provide vital tuition assistance for the 2026-2027 school year. Your commitment to Christ-centered education has already made a lasting difference in the lives of many families and students.

With your continued partnership, we have an exciting opportunity ahead: ILSTO aims to raise \$1,165,935 in 2026! Your donations are more impactful than ever—every contribution qualifies for a generous 75% Iowa tax credit!

Scholarship Opportunities

Iowa District West offers financial aid for students preparing for church work at any Concordia University or one of our seminaries. Grants may also be available for non-church-work Concordia students as funds allow. Requirements are as follows:

- Member in good standing of an Iowa West LCMS congregation
 - Enrolled at a Concordia University System school or LCMS seminary
 - Submit application and pastor's recommendation by **June 1**
- Applications are available on the district website www.idwlcms.org (Resources → Forms and Links Tab).
Questions? Email Pastor Joseph Pierson at revpierson@gmail.com.

Camp Okoboji is now recruiting staff for the Summer 2026 camp season. Youth 16 and older and college students are encouraged to explore opportunities to serve on the Camp Okoboji team. Individuals interested in serving at Camp Okoboji—or at any LCMS camp in 2026—should begin by completing a NLOMA profile. This profile serves as the first step in the application and consideration process for summer positions. Fill out a profile online at <https://nloma.org/employment/summer/serviceprofile/>



Calendar of Events

- January 25-31...Lutheran Schools Week Dodge
- January 29...Board of Directors Meeting, District Office, Fort Dodge
- February 9...Mutual Consolation Conference, Immanuel Lutheran, Rockwell City
- February 18....Ash Wednesday, Lent Begins



For more information on Iowa District West activities, view *The Messenger* at www.idwlcms.org/publications.php

Refocus for Lent

- Give up complaining — focus on gratitude.
- Give up harsh judgments — think kind thoughts.
- Give up worry — trust God to provide.
- Give up discouragement — be full of hope.
- Give up bitterness — turn to forgiveness.
- Give up hatred — return good for evil.
- Give up anger — be more patient.
- Give up pettiness — become mature.
- Give up jealousy — pray for trust.
- Give up gossiping — control your tongue.
- Give up sin — turn to virtue.
- Give up giving up — persevere.

—Author unknown

Mealtime as a family

Amid busy and varied schedules, many families find a way to sit down together for dinner regularly. Family-health advocates describe the benefits: an increased sense of unity, children sharing news and feeling listened to, and the physical perks of a planned, seated meal.

In Scripture, many great encounters between people and God happen around meals. Abraham and Sarah prepare a meal for three guests who turn out to be angels (Genesis 18). God instructs the Hebrew slaves to eat a special meal together before their delivery from Egypt (Exodus 12); every year since, Jews have celebrated the Passover feast. Elijah is strengthened with food served by an angel (1 Kings 19). Jesus shares meals not only with religious leaders but with “sinners” (e.g., Matthew 9). Jesus’ Last Supper with his disciples before his death has become one of the church’s sacraments and a “foretaste” of the heavenly banquet to come.

When Christian families eat together, it’s a holy time in God’s presence, just as when the church shares Holy Communion — a true fellowship dinner!

“Teach us to love”

O God, perfect us in love,
That we may conquer all selfishness and hatred of others;
Fill our hearts with thy joy,
And shed abroad in them thy peace which passeth understanding;
That so those murmurings and disputings
To which we are too prone may be overcome.
Make us long-suffering and gentle,
And thus subdue our hastiness and angry tempers,
And grant that we may bring forth the blessed fruits of the Spirit,
To thy praise and glory, through Jesus Christ our Lord. Amen.

—Rev. Henry Alford (1810-1871)

FEBRUARY

	MONDAY	TUESDAY	WEDNESDAY	THURSDAY	FRIDAY	SATURDAY
9:00 Chr Ed						
1 9:00 Chr Ed 10:00 DW/HC 11:00 Council Meeting	2	3	4 1:30 Evening Circle 3:00 Make Subs	5	6	7
8 9:00 Chr Ed 10:00 DW/HC	9	10	11 6:30 Midweek Class	12	13	14 HAPPY Valentine's Day
15 9:00 Chr Ed 10:00 DW/HC	16	17	18 6:30 Ash Wed Service/HC	19	20	21
22 9:00 Chr Ed 10:00 DW/HC	23	24	25 6:30 Midweek Lenten Service	26	27	28

USHERS

Dwight Ehlers Randy Neumann
 Brian Kraus Jake Kraus
 Curtis Ehlers Dale Lenz
 Zack Kraus Devon Ehlers
 Riley Neumann Ryan Neumann

Parish Circle

Paulette Von Glan
 Marilyn Mueggenberg
Chancel Circle
 Paulette Von Glan
 Marilyn Mueggenberg

ACOLYTES

2/1 Sutton Wittrock
 2/8 Kylee
 2/15 Kaleb
 2/18 Brandt (Ash Wednesday)
 2/22 Joe
 2/25 Sebastian (Wed)

Super Bowl

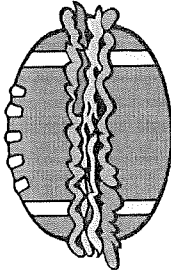

Subs

**Make Subs on 2/4/26 for
 Super Bowl on 2/8**

Zion Lutheran Church
118 W Tracy St
Box 59
Arcadia, IA 51430
712-689-2441
zionluth@westianet.net

Non-Profit Organization
Arcadia, IA 51430
Standard Mail

<i>Friends Who Care</i>	
<i>Christian Education</i>	<i>9:00 am</i>
<i>Divine Worship</i>	<i>10:00 am</i>

FRIENDS ARE

TRUTHFUL
CARING
RELIABLE
HELPFUL
POLITE
INTERESTING
ALWAYS THERE
FOR YOU.